

# **P10 SERIES**

## **VEHICLE SECURITY SYSTEM PRODUCT MANUAL**

## Limited Lifetime Warranty

This vehicle security system is warranted to the original purchaser, to be free from defects in material and workmanship. The manufacturer will repair or replace at its option, and free of charge for the first twelve (12) months, any part that proves defective in material or workmanship under normal installation, use, and service, provided the product is returned to the manufacturer freight prepaid. After the first 12 month warranty period there will be a maximum service charge of \$25.00 per calendar year (if required) for repair and/or replacement of any defective parts.

A copy of the original purchase receipt must accompany any products returned for warranty service. Warranty is limited to defective parts and/or replacement parts only and excludes any incidental, and consequential damages connected therewith.

The manufacturer of this theft deterrent system makes no warranty against the theft of the vehicle or its contents. This warranty is not to be construed as an insurance policy against loss.

WARRANTY OF INSTALLATION LABOR, REMOVAL AND RE-INSTALLATION CHARGES ARE NOT THE RESPONSIBILITY OF THE MANUFACTURER.

# Table of Contents

1.	About Your System	Page 1
2.	Remote Transmitters	Page 2
	Remote Transmitter Description	Page 2
	Adding/Replacing Transmitters	Page 3
3.	System Operation	Page 4
	Remote Arming	Page 4
	Remote Disarming	Page 4
	Silent Arming/Disarming	Page 4
	Passive Arming	Page 5
	Panic Mode	Page 5
	Emergency Override	Page 6
	Optional Coded Emergency Override	Page 6
	Valet Mode	Page 6
	Battery Replacement	Page 6
4.	Extended Features	Page 7
	Ignition Controlled Door Locks	Page 7
	Dome Light Activation	Page 7
	Auxiliary Function Outputs	Page 7
	Remote Sensor Disable	Page 7
	Anti-Carjacking Protection	Page 7
5.	System Installation	Page 8
	Mounting the Control unit	Page 9
	Mounting the Siren	Page 9
	Mounting the Shock Sensor	Page 9
6.	System Wiring	Page 10
	14-Pin Main Harness	Page 10
	Plug-in Connectors	Page 10
7.	System Programming	Page 11
	Entering System Programming	Page 11
	Default Reset	Page 11
	Programmable System Options	Page 11
	Branch Table	Page 11
8.	Door Lock Diagrams	Page 13
9.	Wiring Diagram	Back Page
10.	Technical Information	Back Page



# About Your System

Congratulations on your purchase of this state-of-the-art vehicle security system . With proper installation this system will provide superior protection and performance for many years to come.

## System Contents:

- Main Unit
- Two 2-Button Remote Transmitters
- High Output 6-tone Siren
- Dual Stage Shock Sensor
- Status LED
- Valet Switch

## Options and Accessories\*

This system includes several optional inputs and outputs allowing the creation of a completely personalized security and convenience system by offering many optional features such as:

**\*May require additional parts and/or labor, see store for details.**

- Remote Door Locking
- Two Stage Door Unlocking
- Starter Defeat
- Horn Honk
- Illuminated Entry
- Remote Car Start
- Extended Range Antenna
- Power Trunk / Hatch Release
- Radar Sensor
- Back-up Battery Siren

### PLEASE NOTE:

Some of the features described in this manual may require additional parts and/or labor, and may not be included as part of the standard installation of this unit. Additionally, many features of this security system have selectable options that must be activated or programmed during the system's installation. These items will be identified in the following sections. Please discuss these features and any questions you may have regarding the installation of this product with Your Authorized Dealer.

# Remote Transmitters

## Remote Transmitter Description

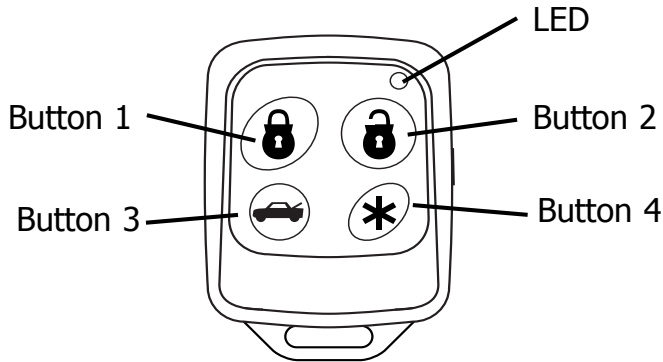

The A10-4B is supplied with two 4-button Remote Transmitters used to control system operations.

*Button 1* Arms the system and when held for 2 seconds, activates the system's Panic feature. Button 1 also locks the doors when the system is in Valet Mode.

*Button 2* Disarms the system. Button 2 also unlocks the doors when the system is in Valet Mode.

*Button 3* Activates the Auxiliary 1 output. This output will remain on for as long as the button is pressed.

*Button 4* Activates and deactivates car-jack if car-jack feature is enabled.

## Adding/Replacing Transmitters

To replace lost or stolen transmitters or to add additional transmitters into the system, have all desired transmitters ready and follow the steps below.

**Note:** Up to 4 transmitters can be programmed to operate the system. To erase any previously stored transmitter codes, be sure to program all 4 transmitter memory locations.

To program the transmitter(s):

1. Turn on the ignition key On, Off, On, Off, and back On.
  - The siren will chirp 3 times.
2. Press and hold the Override switch for 5 seconds.
  - The siren will chirp 5 times.
  - The LED will illuminate.
3. Press Button 1 on the first transmitter.
  - The siren will chirp once.
4. Repeat steps 3 for each transmitter (up to 4).
5. Turn off the ignition key.



# System Operation

## **Remote Arming**

The system monitors 3 independent areas (**zones**) while armed: doors, hood/trunk, and shock sensor input.

To Arm the System:

1. Turn off the ignition.
2. Press Button 1.
  - The siren will chirp once.\*
  - The doors will lock.
  - The parking lights will flash once.
  - The LED will turn on red, to indicate the starter defeat is activate.
3. 5 seconds after Arming:
  - The LED will start blinking to indicate that the doors and hood/trunk inputs are being monitored.

\* **During Arming, if the system detects a bad sensor or an open zone, the system will chirp 4 additional times and ignore that input, but keep all other areas protected.**

Once Armed, the alarm will trigger when any of the following occurs:

- **The doors are opened.**
- **The hood or trunk is opened.**
- **The shock sensor detects an impact to the vehicle.**

When the alarm triggers, the siren will sound, the horn will honk, and the parking lights will flash. If the system is triggered by the doors, or hood/trunk, the system will alarm for 45 seconds. If triggered by the shock sensor input, the system will alarm for 30 seconds.

In the event the alarm is triggered and remains triggered continuously by the same sensor or input during a single arming cycle, that sensor or input will be automatically bypassed until the next time the system is armed.

If the Shock Sensor detects a light impact to the vehicle, the siren will chirp 5 times as a warning indication.

## **Remote Disarming**

To Disarm the System:

Press Button 2.

- The siren will chirp twice.\*
- The doors will unlock.
- The parking lights will flash twice.
- The dome light will turn on.
- The LED will turn off.

\* **During Disarming, if the system was triggered while away from the vehicle, the siren will chirp 3 times, and the parking lights will flash 3 times.**

## **Passive Arming**

When programmed for the optional Passive Arming feature, the system arms itself automatically, each time the ignition is turned off and all of the doors, hood, and trunk are closed.

To start the Passive Arming Process:

1. Turn off the ignition.



2. Open the door and exit the vehicle.
  - Once all doors are closed and the dome light is off, the LED will begin flashing rapidly.
3. After 30 seconds,
  - The siren will chirp.
  - The parking lights will flash.
  - The doors will lock.\*
  - The status LED will begin flashing.
4. The system is now armed.
  - \* **If the Passive Locking feature is selected.**

If the Passive Arming with Countdown feature is programmed, the siren will chirp every 2 seconds until the system passively arms.

**Note: If the Passive Arming feature is enabled, the Automatic Rearming feature will also be enabled even if it was not already programmed.**

### ***Panic Mode***

In the event of an emergency the transmitter's Panic feature can be used to instantly trigger the alarm.

To activate the Panic Mode:

1. Press and hold Button 1 for 3 seconds.
  - The alarm will sound.
  - The parking lights will flash.
  - The doors will unlock\* allowing access to the vehicle.
2. Press Button 2 to stop Panic Mode.

\* **If the ignition is on when the Panic feature is activated, the doors will lock for personal safety.**

### ***Emergency Override***

If the transmitter is lost or inoperable, the system can still be disarmed using the following procedure. Before beginning this procedure be sure to have the ignition key ready and know the location of the override switch.

To Emergency Override the system:

1. Unlock the door using the key.
2. Enter the vehicle.
  - The system will trigger and the siren will sound.
3. Turn ignition key on.
4. Press and hold the override switch for 10 seconds.
  - The system will disarm.
5. The vehicle will now be able to start.

### ***Optional Coded Emergency Override***

As an extra measure of security, the system is equipped with an optional Coded Emergency Override feature. Once an Emergency Override Code is chosen and programmed during installation, the system can no longer be disarmed using the standard override procedure.

To Emergency Override the system using the Code:

1. Follow steps 1-3 above.
2. Press the override switch a number of times equal to the Disarm code, and continue holding for 10 seconds on the last press.

- The system will disarm. If the code is entered incorrectly, turn off the ignition and begin again.

To set the Emergency Override Code:

1. Turn on ignition.
2. Within 5 seconds, press the valet switch 5 times.
  - The siren will provide one long chirp, indicating that you have entered Programming.
3. Press the valet switch 3 times.
  - The siren will chirp each time the valet switch is pressed.
4. Within 5 seconds, press Button 3 on the transmitter.
  - The siren will chirp 3 times.
5. Press the valet switch the number of time equal to the desired code (from 1-15).
6. Turn off the ignition then arm the system.
7. Disarm the system using the new Override Code to permanently store the new code.

**Note: If the code set procedure is not properly performed, turn off the ignition and begin again. The override code will not be permanently stored until the code is used to disarm the system.**

## ***Valet Mode***

The Valet Mode temporarily disables the security system so the vehicle may be operated by a mechanic or parking attendant.

To activate or deactivate the Valet Mode:

1. Turn on the ignition.
2. Press and hold the override switch for 5 seconds.
  - The siren will chirp once to confirm the Valet Mode is on.
  - The siren will chirp twice to confirm the Valet Mode is off.
3. Turn off the ignition.

While in Valet Mode the remote transmitters will continue to lock and unlock the doors, and operate the optional auxiliary functions.

## ***Battery Replacement***

Your Remote Transmitter uses a 2 of 3 volt battery (type CR2016 ), which will require replacement in time. Depending on the amount of use, the battery may last up to six months or more before it needs replacement.

When the battery needs replacing, the system's operating range will decrease or the transmitter LED may not be as bright.

In order to change the battery, separate the top and bottom halves of the case.

While replacing the battery make sure that the positive and negative terminals are positioned correctly, then carefully reassemble the transmitter case.

## Extended Features

### ***Ignition Controlled Door Locks***

For added safety, the Ignition Door Locking feature allows vehicles equipped with power door lock systems to automatically lock the doors when the ignition is turned on, and unlock the doors after the ignition key is turned off. If a door is open when the ignition is turned on, the ignition locking feature is disabled to protect against locking the keys inside the vehicle.

### ***Dome Light Activation***

If the optional Dome Light Activation feature is installed, the dome light will turn on when the system is disarmed using the Remote Transmitter. The dome light will remain on for 30 seconds or until the ignition is turned on.

### ***Auxiliary Function Outputs***

The A10-4B system is equipped with an Auxiliary Output allowing the convenience features of the system to be further expanded. This output can be used to add an optional feature such as: power trunk release, remote engine start, power window activation, power sunroof control, etc.

### ***Remote Sensor Disable***

When parking the vehicle in areas susceptible to unwanted disturbance from animals or strong weather conditions that could cause the sensors to trigger, the sensor inputs can be temporarily bypassed using the Remote Transmitter, preventing possible false alarms.

To disable the sensor inputs :

1. Arm the system normally.
2. Within 5 seconds of Arming the system, press the Arm button again.
  - The siren will chirp 5 times and the parking lights will flash 5 times to indicate the sensors are disabled.
  - The sensors will remain disabled until the next arming cycle.

### ***Anti-Carjacking Protection***

For a higher level of personal security, the system is equipped with three programmable Anti-Carjacking modes. When any Anti-Carjacking mode is triggered, the parking lights will flash twice to confirm activation. After 90 seconds the siren will begin chirping for 15 seconds as a warning, prior to entering full alarm mode. During the full alarm mode, the siren will sound, the parking lights will flash, and the horn will honk for up to five minutes or until the system is reset.

**Manual.** When selected, activating the button 4 will automatically trigger the Anti-Carjacking feature. Press the button 4 again to reset the Manual Anti-Carjacking mode.

**Passive.** When selected, the Anti-Carjacking feature will activate whenever a door is opened while the ignition is on. Press the Valet switch to reset the Passive Anti-Carjacking mode.

**Full-Time.** When selected, the Anti-Carjacking feature will automatically activate each time the ignition is turned on. Press the Valet switch while the ignition is on to reset the Passive Anti-Carjacking mode.

**Note:** The desired Anti-carjacking mode must be programmed during installation.

# System Installation

1. Thoroughly read and become familiar with the installation instructions before beginning the installation.
2. Review system contents:
  - Main Unit
  - Two 2-Button Remote Transmitters
  - Siren
  - Shock Sensor
  - Harnesses
    - 8-Pin main harness
    - 4-Pin main harness
    - 4-Pin shock sensor harness
    - 3-Pin door lock harness
    - LED harness
    - Override Switch harness
3. Verify with the owner, the mounting locations for all visible components, including the LED and Override switch.
4. Verify with the owner, the optional features of the A10-4B and the features that must be programmed during installation.
5. Inspect and perform a function test of all vehicle systems before and after the installation.
6. Always use a Volt / Ohm meter for testing vehicle circuits. Never use a test light.
7. Always look before drilling any holes or mounting self-tapping screws. Be sure fuel lines and exterior wiring looms are clear as they are often close to the chassis and difficult to see.
8. Protect all wires running from the engine compartment to the interior of the vehicle by covering with electrical tape and split loom tubing. Be sure to use a grommet when routing wires through the firewall.
9. Properly fuse any additional accessories such as window modules, door lock actuators, etc., making sure to power them separate from the alarm module. This will ensure the functionality of the security system in the event of an accessory failure.

## ***Mounting the Control Unit***

The control unit must only be mounted in the interior of the vehicle. Do not mount the main unit in the engine compartment. Choose a mounting location that will not be easily accessible to a thief, and will not interfere with the operation of any vehicle components such as foot pedals, steering column, air vents, seat rails, etc.

Do not mount the control unit until after setting the internal jumpers and performing a complete operation check of the system. After installation is complete and performance verified, the control unit can be easily mounted using wire ties through the mounting tabs on the bottom of the unit.

## ***Mounting the Siren***

Choose a siren mounting location that is away from heat sources such as exhaust manifolds, and where it cannot be easily accessed from underneath the vehicle. Be sure to face the siren downward to prevent the collection of water in the siren's housing.

Always route all wires from the engine compartment into the interior of the vehicle through a proper grommet.

## ***Mounting the Shock Sensor***

Choose a suitable interior mounting location for the shock sensor that provides ample coverage of the vehicle. Keep the sensor away from the vehicle's ECM or other sources of electrical interference. Suggested mounting locations include air conditioning ducts, dashboard braces, or center console supports.

During proper operation, the shock sensor will detect impacts to the vehicle only and will not usually be triggered by slow rocking movements of the vehicle like those caused by wind.

# System Wiring

## **8-Pin Main Harness**

- Pin 1 **ORANGE WIRE:** Armed Output (-) 500mA. The ORANGE wire provides a ground output while armed to activate an optional starter defeat relay or other device such as a power window control module.
- Pin 2 **BLUE WIRE:** Trunk/Hood trigger Input (-). Connect the BLUE wire to the trunk and/or optional hood pin switches. The switch must provide a ground output when opened.
- Pin 3 **BLACK/WHITE WIRE:** Dome Light Output (-) 500mA. Connect to an optional relay for dome light activation. NOTE: The output from the optional dome light relay may usually connected to the same wire used for the door trigger input (See GREEN and VIOLET door trigger wires).
- Pin 4 **BROWN/WHITE WIRE:** Horn Output (-) 500mA. Connect to an optional relay to activate the vehicle's horn when the alarm is triggered.
- Pin 5 **GRAY WIRE:** Auxiliary 1 Output (-) 500mA. Connect to a relay or module for an optional feature such as trunk release, etc.
- Pin 6 **BROWN WIRE:** Siren Output (+) 3A. The BROWN wire must connect to the siren's red wire. The BLACK siren wire must be grounded.
- Pin 7 **GREEN WIRE:** Negative door trigger Input (-). Connect to the door switch circuit wire that shows ground when the door is open.
- Pin 8 **VIOLET WIRE:** Positive door trigger Input (+). Connect to the door switch circuit wire that shows +12V when the door is open. This type of door circuit is usually found on Ford vehicles.

## **4-Pin Main Harness**

- Pin 1 **WHITE WIRE:** Parking Light Output (+)10A. The WHITE wire must connect to the circuit that shows +12V when only the parking lights are on. For parking light circuits exceeding 7 amps, a relay is required. For vehicle's with independent left and right parking light circuits, diodes must be used to keep the circuits separate. NOTE: Do not connect the WHITE wire to the vehicle's headlight circuit.
- Pin 2 **RED WIRE:** +12V Battery Input (15A Fuse). The RED wire must be connected to a clean source of continuous +12V power.
- Pin 3 **YELLOW WIRE:** +12V Ignition Input. The YELLOW wire must connect to a main ignition wire at the ignition harness. This wire must show +12V when the ignition is on.
- Pin 4 **BLACK WIRE:** Ground Input (-). The BLACK wire must connect to a solid chassis ground. Clean away any paint or dirt to insure the best possible ground.

## **Plug-in Connectors**

**3-Pin White Door Lock Connector:** Plug-in connector port for door lock harness or optional door lock relay module.

- BLUE WIRE - negative unlock output (-) 500mA.
- RED WIRE - constant +12V low current output for relay modules, or inverters. 100mA relay trigger only. Do NOT use as a power source for door lock relays.
- GREEN WIRE - negative lock output (-) 500mA.

**2-Pin Red Connector:** Plug-in connector port for LED. Mount the LED in an area where it may be easily seen from either side of the vehicle.

**2-Pin Blue Connector:** Plug-in connector port for valet switch. Mount the valet switch in an area that is easily accessible from the driver's position.

**4-Pin White Connector :** Plug-in connector port for dual stage shock sensor.

# System Programming

## Entering System Programming

To enter System Programming:

1. Turn on ignition.
2. Within 5 seconds, press the valet switch 5 times.
  - The siren will provide one long chirp, indicating that you have entered Programming.
3. Press the valet switch the number times equal to the System Parameter you want to change.
  - The siren will chirp each time the valet switch is pressed.
4. Within 5 seconds, press the transmitter button corresponding to the desired operating mode for that System Parameter.
  - The siren will chirp to indicate the setting.
 

1 chirp	=	Button 1
2 chirps	=	Button 2
3 chirps	=	Button 3
5. When you are finished, turn off the ignition to save the changes.

## Default Reset

Following this procedure will set all System Programming Parameters to factory default settings.

1. Enter System Programming.
2. Press Transmitter Button 3.
  - The siren will chirp 6 times indicating that the reset signal was received.
  - All System Programming parameters are now set to factory default settings.
  - The Valet Mode is off.
3. Turn off ignition.

## Programmable System Options

Branch	Feature	Button 1 (default)	Button 2	Button 3
1.	Horn Chirps w/ Arm&Disarm	Horn Chirps Disabled	Horn Chirps Enabled	Horn Chirps w/Warn
2.	Arm Mode	Manual Arming	Passive Arming	Passive w/Countdown
3.	Passive Door Locking	Disabled	Enabled	Set Override Code
4.	Ignition Controlled Locks	On	Off	Lock Only
5.	Door Input Monitoring	10 Seconds	60 Seconds	
6.	Auto Rearming	Disabled	Enabled	
7.	Door Unlock Pulse	Single	Double	
8.	Arming Chirps	Normal	Silent	
9.	Extended Parking Lights	On	Off	
10.	Disarm with Aux 1	Disabled	Enabled	
11.	Door Lock Pulse Length	1 Second	3 Seconds	0.1 Seconds
12.	Anti-Carjack Mode	Disabled	Enabled	
13.	Anti-Carjack Type	Manual	Passive	Full-time
14.	Ignition Armed Mode	Disabled	Enabled	
15.	Interior Light Mode	Interior Light 30Sec	Windows 10Sec	Windows 30Sec

1. **Horn Chirps with Arm & Disarm.** Selects one of three modes: Normal, Horn Chirps, and Horn Chirps w/Warn.  
Normal. When selected, the horn will honk only when the alarm is triggered.  
Horn Chirps. When selected, the horn will provide the arm/disarm and trigger indications, allowing the siren installation to be skipped.  
Horn Chirps w/Warn. When selected, the horn will provide arm/disarm, trigger, and warn-away indications.
2. **Arm Mode.** Selects one of three modes: Manual Arming or Passive Arming, and Passive Arming w/Countdown. With the Passive Arming w/Countdown mode selected, the siren will chirp every 2 seconds while counting down until the system passively arms. Note: If Auto Rearming is selected, the siren will also chirp during Auto Rearm countdown.
3. **Passive Door Locking.** Selects whether or not the system will automatically lock the doors 10 seconds after the ignition key is turned on.
4. **Ignition Controlled Locks.** Selects whether or not the system will lock and unlock the doors with the ignition.
5. **Door Input Monitoring.** Selects whether the system begins monitoring the door inputs after 10 seconds or 60 seconds. For vehicles with interior lights that remain on for an extended period of time after the doors are closed, set for 60 seconds.
6. **Auto Rearming Mode.** When selected, the system will automatically re-arm 30 seconds after it is disarmed if the doors have not been opened.
7. **Door Unlock Pulse.** Selects between one pulse or two pulse operation for the door unlock output. Vehicles that require two pulses on the proper wire to unlock the doors can be interfaced directly without the use of relays or any additional circuitry by programming the system for double unlock pulse.
8. **Arming Chirps.** Selects between normal and silent operation.
9. **Extended Parking Lights.** When selected, the parking lights will remain on for 30 seconds after disarming the system.
10. **Disarm with Auxiliary 1.** When selected, activating the Auxiliary 1 output (usually used to open the trunk) will disarm the alarm.
11. **Door Lock Pulse Length.** Selects between a 1-second and a 3-second output for door locking and unlocking. Program to 3 seconds for vehicles equipped with vacuum door locking systems.
12. **Anti-Carjack Mode.** Enables Anti-Carjacking protection.
13. **Anti-Carjack Type.** Selects one of three modes for Anti-Carjacking: Active, Passive, or Full-Time.  
Manual. When selected, activating the Panic feature will automatically engage the Anti-Carjacking feature.  
Passive. When selected, the Anti-Carjacking feature will activate whenever a door is opened while the ignition is on.  
Full-Time. When selected, the Anti-Carjacking feature will automatically activate each time the ignition is turned on.
14. **Ignition Arm Mode.** Ability to Arm the system with Ignition in On position.
15. **Interior Light Mode.**  
Interior Light 30Sec - Upon Disarming, Interior Light Output turns ON for 30 Sec.  
Windows 10Sec - Upon Arming, Interior Light Output turns ON for 10 Sec.  
Windows 30Sec - Upon Arming, Interior Light Output turns ON for 30 Sec.



# Door Lock Diagrams

Follow the diagrams below for connecting basic door lock systems. For Two Stage door lock systems (separately unlocks driver and passenger doors) see following pages.

## Negative Trigger

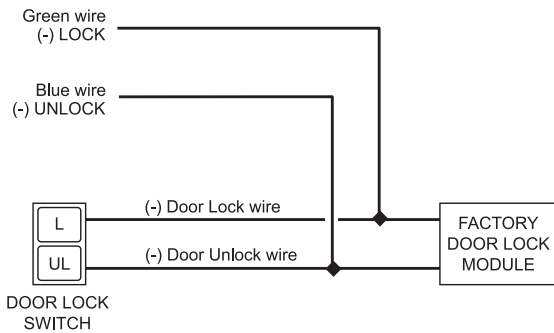

## Adding Actuators

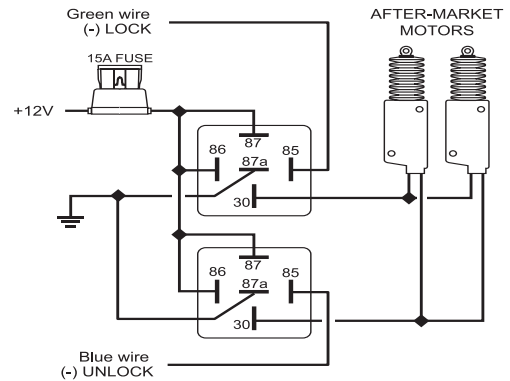

## Reverse Polarity

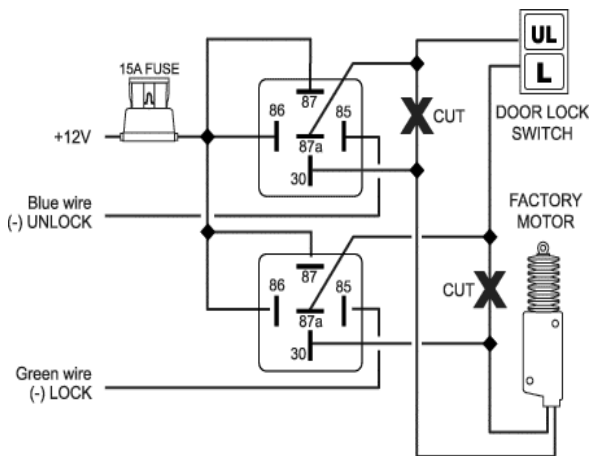

## Vacuum

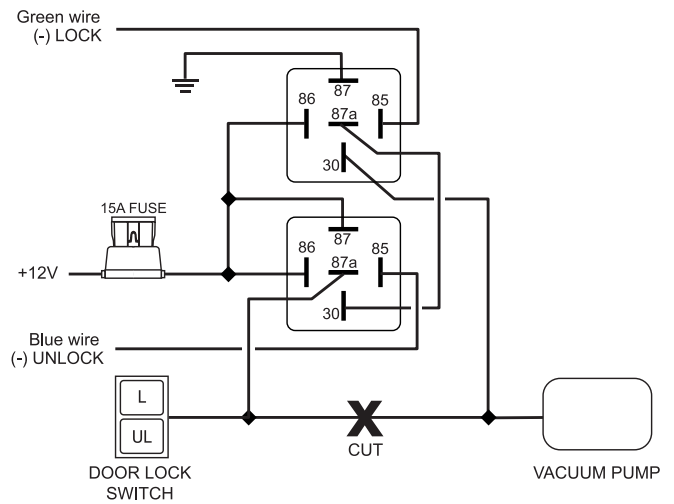

# Starter Interrupt

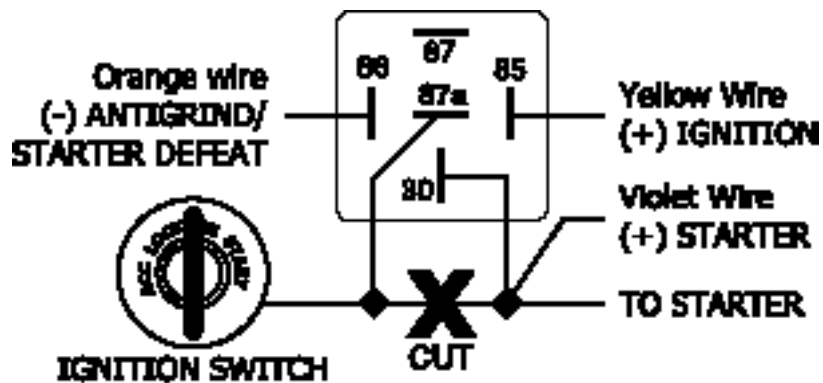

# Wiring Diagrams

Positive Dome Light

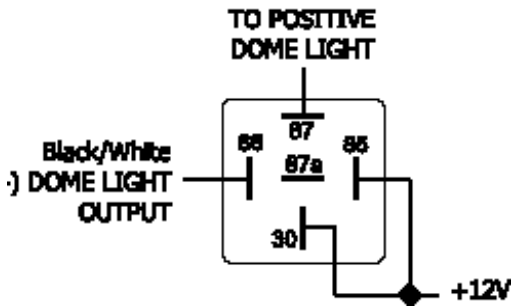

Negative Dome Light

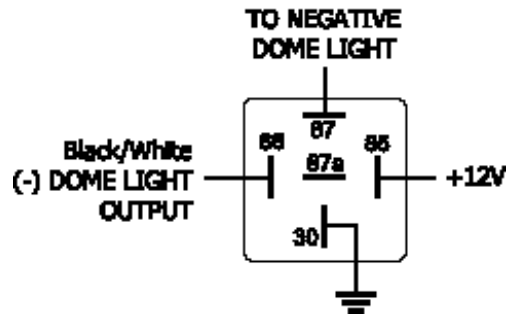

Positive Horn Honk

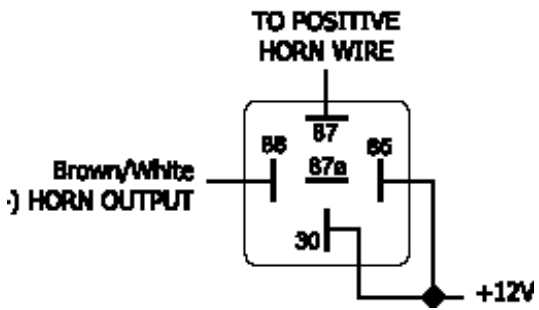

Negative Horn Honk

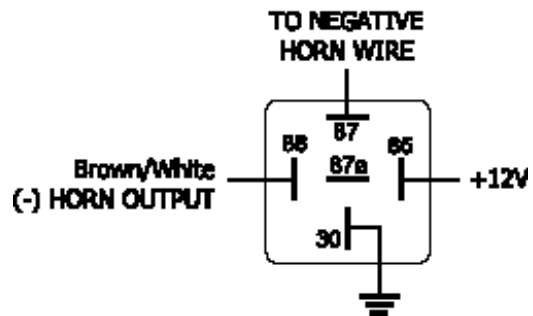



## Wiring Diagram

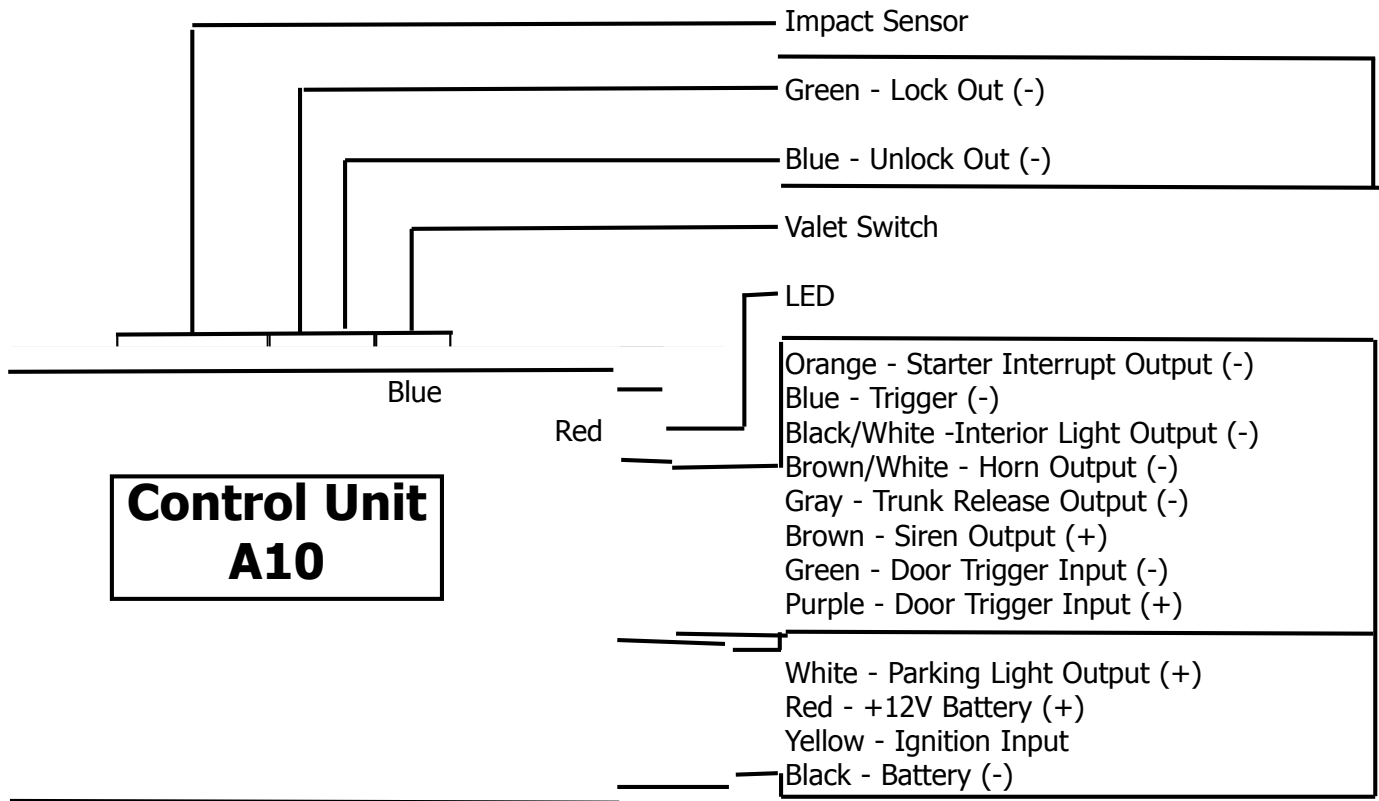

## Technical Information

### FCC ID: OARRXAM2000

This device complies with Part 15 of FCC Rules.

Operation is subject to the following two conditions:

- 1) This device may not cause harmful interference.
- 2) This device must accept any interference received, including interference that may cause undesired operation